



REQUEST FOR FORMAL PRICE QUOTATION

Procurement from R30 000.00 up to a transaction value of R200 000.00
(Including Vat)
(For publication on Pikitup Website and Notice Board)

APPOINTMENT OF General services of maintenance and repairs are required at Pikitup Robinson deep landfill site.

APPOINTMENT OF A SUITABLE SUPPLIER FOR THE SUPPLY OF BRANDED MARKETING COLLATERAL TO BE USED IN PIKITUP
(ANNEXURE A FOR THE FULL DETAILS)

BID NO: PIK 151/2020-21

BIDDER NAME:

BID AMOUNT (VAT INCL): R _____

THIS DOCUMENT IS COMPILED FOR:

Pikitup Johannesburg SOC Ltd
Jorissen Place Building
66 Jorissen Street,
Braamfontein, JHB

CONTACT DETAILS:
Sagren Naidoo

E-mail : sagrennaidoo@pikitup.co.za
Landline : 0873571195
Mobile : 0824312373

QUOTATION BOX SUBMISSION IS SITUATED AT:

Pikitup Johannesburg SOC Ltd
Jorissen Place Building
66 Jorissen Street,
Tender Office
Ground Floor
East Wing
Braamfontein, JHB

Closing date: 04 NOVEMBER 2020
Closing time: 11:00am
Validity Period: 60 days from RFQ closing date
Briefing session: Not applicable

BIDDER'S COMPANY NAME: _____

BIDDER'S CONTACT PERSON: _____

BIDDER'S CONTACT NUMBER: _____

BIDDER'S EMAIL ADDRESS: _____

TOTAL BID AMOUNT: _____

CLOSING DATE: **04 NOVEMBER 2020**

CLOSING TIME: **11:00AM**

BRIEFING SESSION: **Not Applicable**

Document Issued By:

Pikitup Johannesburg SOC Limited
Pikitup Head Office (Ground Floor)
Jorissen Place Building
66 Jorissen Street
Braamfontein

Tel : +27 (0)87 357 1195
E-Mail : sagrennaidoo@pikitup.co.za

Website : www.pikitup.co.za

Quotations received will be evaluated firstly on pre-compliance evaluation, then on functionality evaluation (**IF APPLICABLE**), and thereafter 80/20 point scoring basis. The 80 points will be for Price and 20 points are for Broad Based Black Economic Empowerment (BBBEE) for attaining the BBBEE Status level contribution in accordance with the table below:

- **MBD 4: Declaration of interest**
- **MBD 8: Declaration of bidders past supply management practices**
- **MBD 9: Certificate of Independent bid determination**

Failure to submit a fully compiled **MBD** forms quotation will result in your bid being rejected.

- **No quotation** will be considered from persons in the service of the state (**MBD4**).
- **As from the 7 December 2011**, all Service providers/contractors are required to submit valid, certified copies of their BEE certificate from an accredited BEE verification agency with their bid submission. Failure to submit will lead to forfeiture (loss) of the preference points.
- **In case of an Exempted Micro Enterprise (EME)** (turn over less than R 10m) a letter from a professional registered accountant/ auditor or a sworn affidavit is required in order to qualify for preference points. Failure to submit will lead to forfeiture (loss) of the preference points.

SECTION 2

1. **The Lowest or any bid will not necessarily be accepted** and the **PIKITUP reserves the right not to consider any bid** not suitably endorsed or comprehensively completed as well as the right to accept a bid in whole or part. In addition Pikitup also reserves the right to appoint more than one service provider/supplier as deemed necessary
2. In evaluating bids received and adjudicating the award of this bid, Pikitup Johannesburg (SOC) Limited will, in addition to the pre-compliance and functionality criteria included in the specifications and irrespective of the capital, pricing and black economic empowerment structures of the bidder, take into account as objective criteria (1) the desirability of rotating the work amongst service providers, (2) the past bidding practices of any bidder in relation to evidence and/or reports of combative practices including conduct reported, amongst others, in terms of the Prevention and Combatting of Corrupt Activities Act, 2004, (3) the past contractual performance of any bidder and (4) the nature and extent of disputes involving the bidder in relation to past and/or current contracts. Note that as a result of the application of these objective criteria, the highest scoring bidders will not necessarily be selected as a preferred bidders.
3. Where deliveries are quoted "ex-stock" the period of **delivery must not exceed Five (5) maximum working days after receipt of order. If this condition is not adhered to, the order could be cancelled.**
Quotations are to be completed in accordance with the conditions as set out in the quotation document and must be sealed and externally endorsed with the quotation number and place in the quotation box indicated above.
4. **Payments will be made thirty (30) days** after receipt of invoice by Pikitup.
5. Quotations received after the closing date and time will not be considered
6. Samples of the required items or goods are available for your perusal (when applicable.)
7. Should the above-mentioned conditions not be adhered to, the quotation will be considered invalid.
8. **Quotations must be valid for minimum of 60 days.**

9. It is compulsory for all Service Providers and suppliers wanting to render services to PIKITUP to be registered and have a “compliance status” on the National Treasury Central Supplier Database (“CSD”) as per National Treasury Circular No 3 of 2015/6 – Central Supplier Database. National Treasury will maintain the database of all suppliers for Government and its institutions. Prospective suppliers can register online on the CSD by accessing the National Treasury website at www.CSD.gov.za.

DECLARATION

I, the undersigned hereby confirm that the information herein is a true reflection of the facts presented, and the person signing this document on behalf of the bidder duly authorized to do so. Should this not be the fact, stipulations regarding this as contained in the PIKITUP JOHANNESBURG SOC LTD Policy applies. I accept that the PIKITUP JOHANNESBURG SOC LTD may act against me in terms of the general conditions of contract should this declaration prove to be false.

Signing of the quotation in the appropriate space, as well as the initialing of each page by the bidder mandatory.

NAME OF PERSON

CAPACITY

DATE

**MBD 1
INVITATION TO BID**

**YOU ARE HEREBY INVITED TO BID TO PURCHASE THE AFOREMENTIONED GOODS FROM PIKITUP
JOHANNEBURG SOC LTD**

BID NUMBER:	PIK 151/2020-21	CLOSING DATE:	04 NOVEMBER 2020	CLOSING TIME:	11H00am
-------------	------------------------	---------------	-------------------------	---------------	----------------

**APPOINTMENT OF A SUITABLE SUPPLIER FOR THE SUPPLY OF BRANDED MARKETING
COLLATERAL TO BE USED IN PIKITUP
(ANNEXURE A FOR THE FULL DETAILS)**

THE SUCCESSFUL BIDDER WILL BE REQUIRED TO FILL IN AND SIGN A WRITTEN CONTRACT FORM (MBD7).

**BID RESPONSE DOCUMENTS MAY BE DEPOSITED IN THE
RFQ BOX SITUATED AT JORISSEN PLACE BUILDING,
66 JORISSEN STREET, BRAAMFONTEIN, TENDER OFFICE,
GROUND FLOOR**

SUPPLIER INFORMATION

NAME OF BIDDER					
POSTAL ADDRESS					
STREET ADDRESS					
TELEPHONE NUMBER	CODE		NUMBER		
CELLPHONE NUMBER					
FACSIMILE NUMBER	CODE		NUMBER		
E-MAIL ADDRESS					
VAT REGISTRATION NUMBER					
TAX COMPLIANCE STATUS	TCS PIN:		OR	CSD No:	
B-BBEE STATUS LEVEL VERIFICATION CERTIFICATE [TICK APPLICABLE BOX]	<input type="checkbox"/> Yes		B-BBEE STATUS LEVEL SWORN AFFIDAVIT	<input type="checkbox"/> Yes	
	<input type="checkbox"/> No			<input type="checkbox"/> No	

[A B-BBEE STATUS LEVEL VERIFICATION CERTIFICATE/ SWORN AFFIDAVIT (FOR EMES & QSEs) MUST BE SUBMITTED IN ORDER TO QUALIFY FOR PREFERENCE POINTS FOR B-BBEE]

ARE YOU THE ACCREDITED REPRESENTATIVE IN SOUTH AFRICA FOR THE GOODS /SERVICES /WORKS OFFERED?	<input type="checkbox"/> Yes <input type="checkbox"/> No [IF YES ENCLOSE PROOF]	ARE YOU A FOREIGN BASED SUPPLIER FOR THE GOODS /SERVICES /WORKS OFFERED?	<input type="checkbox"/> Yes <input type="checkbox"/> No [IF YES, ANSWER PART B:3]
TOTAL NUMBER OF ITEMS OFFERED		TOTAL BID PRICE	R
SIGNATURE OF BIDDER	DATE	
CAPACITY UNDER WHICH THIS BID IS SIGNED			
BIDDING PROCEDURE ENQUIRIES MAY BE DIRECTED TO:		TECHNICAL INFORMATION MAY BE DIRECTED TO:	
DEPARTMENT	SCM UNIT	CONTACT PERSON	
CONTACT PERSON	Sagren Naidoo	TELEPHONE NUMBER	
TELEPHONE NUMBER	087 357 1195	FACSIMILE NUMBER	
FACSIMILE NUMBER	N/A	E-MAIL ADDRESS	
E-MAIL ADDRESS	sagrennaidoo@pikutup.co.za		

1. BID SUBMISSION:	
1.1. BIDS MUST BE DELIVERED BY THE STIPULATED TIME TO THE CORRECT ADDRESS. LATE BIDS WILL NOT BE ACCEPTED FOR CONSIDERATION.	
1.2. ALL BIDS MUST BE SUBMITTED ON THE OFFICIAL FORMS PROVIDED–(NOT TO BE RE-TYPED) OR ONLINE	
1.3. THIS BID IS SUBJECT TO THE PREFERENTIAL PROCUREMENT POLICY FRAMEWORK ACT AND THE PREFERENTIAL PROCUREMENT REGULATIONS, 2017, THE GENERAL CONDITIONS OF CONTRACT (GCC) AND, IF APPLICABLE, ANY OTHER SPECIAL CONDITIONS OF CONTRACT.	
2. TAX COMPLIANCE REQUIREMENTS	
2.1 BIDDERS MUST ENSURE COMPLIANCE WITH THEIR TAX OBLIGATIONS.	
2.2 BIDDERS ARE REQUIRED TO SUBMIT THEIR UNIQUE PERSONAL IDENTIFICATION NUMBER (PIN) ISSUED BY SARS TO ENABLE THE ORGAN OF STATE TO VIEW THE TAXPAYER'S PROFILE AND TAX STATUS.	
2.3 APPLICATION FOR THE TAX COMPLIANCE STATUS (TCS) CERTIFICATE OR PIN MAY ALSO BE MADE VIA E-FILING. IN ORDER TO USE THIS PROVISION, TAXPAYERS WILL NEED TO REGISTER WITH SARS AS E-FILERS THROUGH THE WEBSITE WWW.SARS.GOV.ZA.	
2.4 FOREIGN SUPPLIERS MUST COMPLETE THE PRE-AWARD QUESTIONNAIRE IN PART B: 3.	
2.5 BIDDERS MAY ALSO SUBMIT A PRINTED TCS CERTIFICATE TOGETHER WITH THE BID.	
2.6 IN BIDS WHERE CONSORTIA / JOINT VENTURES / SUB-CONTRACTORS ARE INVOLVED, EACH PARTY MUST SUBMIT A SEPARATE TCS CERTIFICATE / PIN / CSD NUMBER.	
2.7 WHERE NO TCS IS AVAILABLE BUT THE BIDDER IS REGISTERED ON THE CENTRAL SUPPLIER DATABASE (CSD), A CSD NUMBER MUST BE PROVIDED.	
3. QUESTIONNAIRE TO BIDDING FOREIGN SUPPLIERS	
3.1. IS THE ENTITY A RESIDENT OF THE REPUBLIC OF SOUTH AFRICA (RSA)?	<input type="checkbox"/> YES <input type="checkbox"/> NO
3.2. DOES THE ENTITY HAVE A BRANCH IN THE RSA?	<input type="checkbox"/> YES <input type="checkbox"/> NO
3.3. DOES THE ENTITY HAVE A PERMANENT ESTABLISHMENT IN THE RSA?	<input type="checkbox"/> YES <input type="checkbox"/> NO

3.4. DOES THE ENTITY HAVE ANY SOURCE OF INCOME IN THE RSA?

YES NO

3.5. IS THE ENTITY LIABLE IN THE RSA FOR ANY FORM OF TAXATION?

YES NO

IF THE ANSWER IS "NO" TO ALL OF THE ABOVE, THEN IT IS NOT A REQUIREMENT TO REGISTER FOR A TAX COMPLIANCE STATUS SYSTEM PIN CODE FROM THE SOUTH AFRICAN REVENUE SERVICE (SARS) AND IF NOT REGISTER AS PER 2.3 ABOVE.

RETURN OF BIDS

Late bids will not be accepted or considered and bids delivered to any other address besides the address stated above will not be considered.

Neither PIKITUP nor any of its employees shall be liable in any way whatsoever for bids that are not placed in the bid box by the closing date and time.

No bid shall be considered unless it is accompanied by sufficient information to show that the goods offered comply with the specification.

Bidders must state the country of origin and the name of the manufacturer of the goods offered. Documentary proof must be produced, if required.

Bidding documents must be completed properly in permanent black ink pen.

VALIDITY PERIOD

Your bid submission must remain valid for a period of 90 days from the closing date of this bid. It will constitute an offer which remains open for acceptance during the validity period.

INFORMATION MEETING

None.

ADJUDICATION OF BIDS

Bids submitted in response to this invitation will be adjudicated by PIKITUP in terms of a supply chain management policy developed in accordance with the requirements of the Municipal Finance Management Act 56 of 2003 and the PPPFA. Enquiries in respect of the policy should be addressed to the Head of PIKITUP's Supply Chain Management -

CONTRACT

The terms of the proposed contract with PIKITUP are contained in the General Conditions of Contract, the Special Conditions of Contract and any of the sections of these bidding documents in which the bidder makes an undertaking as to its performance. You must read and understand the terms before you submit your bid as you will be bound by the Contract (as described) if your bid is successful. At the time of award the contract may include other relevant terms and conditions.

ADMINISTRATIVE JUSTICE

In adjudicating bids, PIKITUP shall comply with the requirements of the Promotion of Administrative Justice Act 3 of 2000 and the Promotion of Access to Information Act 2 of 2000, to the extent that these Acts apply to the adjudication by a municipal entity of bids in response to a bid invitation.

INTERNAL APPEAL PROCESS

Following the adjudication of bids and selection of a preferred bidder, and provided that a procurement contract has not already entered into force, any bidder may submit a complaint in writing to the chairperson of the PIKITUP Board of Directors (“the Board”) or the Managing Director that PIKITUP has not complied with the requirements of the PIKITUP Supply Chain Management Policy or the PIKITUP Code of Ethics, or has in any respect acted in a way that is irregular. The Chairperson of the Board or Managing Director shall not entertain a complaint unless it was submitted within 20 calendar days of when the supplier or contractor submitting it became aware of the circumstances giving rise to the complaint or of when that supplier or contractor should have become aware of those circumstances, whichever is earlier; or entertain a complaint after the procurement contract has entered into force.

Unless the complaint is resolved by mutual agreement of the bidder and the Chairperson of the Board or Managing Director, the Chairperson of the Board shall, within 30 calendar days after the submission of the complaint, issue a written decision. The decision shall state the reasons for the decision; and if the complaint is upheld in whole or in part, indicate the corrective measures that are to be taken.

The decision of the Chair of the Board shall, subject to the review powers of any competent court, be final.

DECLARATION BY BIDDER:

WE HAVE READ THE CLAUSES SET OUT ABOVE IN THIS OF THE BIDDING DOCUMENTS AND ACCEPT THEIR CONTENTS, SUBJECT TO ANY DECLARATION, WE HEREBY OFFER TO CONTRACT WITH PIKITUP ON THE TERMS SET OUT IN THE BIDDING DOCUMENTS SHOULD WE BE APPOINTED AS THE SUCCESSFUL BIDDER.

WITNESSES:

1.

2.

<p>----- AUTHORISED SIGNATURE</p>

CAPACITY OF SIGNATORY

DATE:

ADDRESS
.....

DECLARATION OF INTEREST

- 1. No bid will be accepted from persons in the service of the state¹.
- 2. Any person, having a kinship with persons in the service of the state, including a blood relationship, may make an offer or offers in terms of this invitation to bid. In view of possible allegations of favoritisms, should the resulting bid, or part thereof, be awarded to persons connected with or related to persons in service of the state, it is required that the bidder or their authorised representative declare their position in relation to the evaluating/adjudicating authority.
- 3 In order to give effect to the above, the following questionnaire must be completed and submitted with the bid.**

3.1 Full Name of bidder or his or her representative:

3.2 Identity Number:

3.3 Position occupied in the Company (director, trustee, hareholder²):

3.4 Company Registration Number:

3.5 Tax Reference Number:

3.6 VAT Registration Number:

3.7 The names of all directors / trustees / shareholders members, their individual identity Numbers and state employee numbers must be indicated in paragraph 4 below.

3.8 Are you presently in the service of the state? **YES / NO**

3.8.1 If yes, furnish particulars.

.....

¹MSCM Regulations: "in the service of the state" means to be –

- (a) a member of –
 - (i) any municipal council;
 - (ii) any provincial legislature; or
 - (iii) the national Assembly or the national Council of provinces;
- (b) a member of the board of directors of any municipal entity;
- (c) an official of any municipality or municipal entity;
- (d) an employee of any national or provincial department, national or provincial public entity or constitutional institution within the meaning of the Public Finance Management Act, 1999 (Act No.1 of 1999);
- (e) a member of the accounting authority of any national or provincial public entity; or
- (f) An employee of Parliament or a provincial legislature.

² Shareholder" means a person who owns shares in the company and is actively involved in the management of the company or business and exercises control over the company.

3.9 Have you been in the service of the state for the past twelve months? **YES / NO**

3.9.1 If yes, furnish particulars

.....
 3.10 Do you have any relationship (family, friend, other) with persons
 In the service of the state and who may be involved with
 The evaluation and or adjudication of this bid? **YES / NO**

3.10.1 If yes, furnish particulars.

3.11 Are you, aware of any relationship (family, friend, other) between
 Any other bidder and any persons in the service of the state who
 May be involved with the evaluation and or adjudication of this bid? **YES / NO**

3.11.1 If yes, furnish particulars

3.12 Are any of the company's directors, trustees, managers,
 Principle shareholders or stakeholders in service of the state? **YES / NO**

3.12.1 If yes, furnish particulars.

3.13 Are any spouse, child or parent of the company's directors?
 Trustees, managers, principle shareholders or stakeholders
 In service of the state? **YES / NO**

3.13.1 If yes, furnish particulars.

3.14 Do you or any of the directors, trustees, managers,
 Principle shareholders, or stakeholders of this company
 Have any interest in any other related companies or
 Business whether or not they are bidding for this contract. **YES / NO**

If yes, furnish particulars.....

4. Full details of directors / trustees / members / shareholders.

Full Name	Identity Number	State Employee Number
-----------	-----------------	-----------------------

.....
Signature

.....
Date

.....
Capacity

.....
Name of Bidder

MBD 8

DECLARATION OF BIDDER'S PAST SUPPLY CHAIN MANAGEMENT PRACTICES

- 1 This Municipal Bidding Document must form part of all bids invited.
- 2 It serves as a declaration to be used by municipalities and municipal entities in ensuring that when goods and services are being procured, all reasonable steps are taken to combat the abuse of the supply chain management system.
- 3 The bid of any bidder may be rejected if that bidder, or any of its directors have:
 - a. abused the municipality's / municipal entity's supply chain management system or committed any improper conduct in relation to such system;
 - b. been convicted for fraud or corruption during the past five years;
 - c. willfully neglected, reneged on or failed to comply with any government, municipal or other public sector contract during the past five years; or
 - d. Been listed in the Register for Tender Defaulters in terms of section 29 of the Prevention and Combating of Corrupt Activities Act (No 12 of 2004).
- 4 **In order to give effect to the above, the following questionnaire must be completed and submitted with the bid.**

Item	Question	Yes	No
4.1	<p>Is the bidder or any of its directors listed on the National Treasury's Database of Restricted Suppliers as companies or persons prohibited from doing business with the public sector?</p> <p>(Companies or persons who are listed on this Database were informed in writing of this restriction by the Accounting Officer/Authority of the institution that imposed the restriction after the <i>Audi alter am partum</i> rule was applied).</p> <p>The Database of Restricted Suppliers now resides on the National Treasury's website (www.treasury.gov.za) and can be accessed by clicking on its link at the bottom of the home page.</p>	Yes <input type="checkbox"/>	No <input type="checkbox"/>
4.1.1	If so, furnish particulars:		
4.2	<p>Is the bidder or any of its directors listed on the Register for Tender Defaulters in terms of section 29 of the Prevention and Combating of Corrupt Activities Act (No 12 of 2004)?</p> <p>The Register for Tender Defaulters can be accessed on the National Treasury's website (www.treasury.gov.za) by clicking on its link at the bottom of the home page.</p>	Yes <input type="checkbox"/>	No <input type="checkbox"/>
4.2.1	If so, furnish particulars:		
4.3	<p>Was the bidder or any of its directors convicted by a court of law (including a court of law outside the Republic of South Africa) for fraud or corruption during the past five years?</p>	Yes <input type="checkbox"/>	No <input type="checkbox"/>

4.3.1	If so, furnish particulars:		
Item	Question	Yes	No
4.4	Does the bidder or any of its directors owe any municipal rates and taxes or municipal charges to the municipality / municipal entity, or to any other municipality / municipal entity, that is in arrears for more than three months?	Yes <input type="checkbox"/>	No <input type="checkbox"/>
4.4.1	If so, furnish particulars:		
4.5	Was any contract between the bidder and the municipality / municipal entity or any other organ of state terminated during the past five years on account of failure to perform on or comply with the contract?	Yes <input type="checkbox"/>	No <input type="checkbox"/>
4.7.1	If so, furnish particulars:		

CERTIFICATION

I, THE UNDERSIGNED (FULL NAME) CERTIFY THAT THE INFORMATION FURNISHED ON THIS DECLARATION FORM TRUE AND CORRECT.

I ACCEPT THAT, IN ADDITION TO CANCELLATION OF A CONTRACT, ACTION MAY BE TAKEN AGAINST ME SHOULD THIS DECLARATION PROVE TO BE FALSE.

.....
Signature

.....
Date

.....
Position

.....
Name of Bidder

MBD 9

CERTIFICATE OF INDEPENDENT BID DETERMINATION

- 1 This Municipal Bidding Document (MBD) must form part of all bids¹ invited.
- 2 Section 4 (1) (b) (iii) of the Competition Act No. 89 of 1998, as amended, prohibits an agreement between, or concerted practice by, firms, or a decision by an association of firms, if it is between parties in a horizontal relationship and if it involves collusive bidding (or bid rigging).² Collusive bidding is a *per se* prohibition meaning that it cannot be justified under any grounds.
- 3 Municipal Supply Regulation 38 (1) prescribes that a supply chain management policy must provide measures for the combating of abuse of the supply chain management system, and must enable the accounting officer, among others, to:
 - A. take all reasonable steps to prevent such abuse;
 - b. reject the bid of any bidder if that bidder or any of its directors has abused the supply chain management system of the municipality or municipal entity or has committed any improper conduct in relation to such system; and
 - C. cancel a contract awarded to a person if the person committed any corrupt or fraudulent act during the bidding process or the execution of the contract.
- 4 This MBD serves as a certificate of declaration that would be used by institutions to ensure that, when bids are considered, reasonable steps are taken to prevent any form of bid-rigging.
- 5 In order to give effect to the above, the attached Certificate of Bid Determination (MBD 9) must be completed and submitted with the bid:

MBD 9

CERTIFICATE OF INDEPENDENT BID DETERMINATION

I, the undersigned, in submitting the accompanying bid:

(Bid Number and Description)

in response to the invitation for the bid made by:

(Name of Municipality / Municipal Entity)

do hereby make the following statements that I certify to be true and complete in every respect:

I certify, on behalf of:

that:

(Name of Bidder)

1. I have read and I understand the contents of this Certificate;
2. I understand that the accompanying bid will be disqualified if this Certificate is found not to be true and complete in every respect;
3. I am authorized by the bidder to sign this Certificate, and to submit the accompanying bid, on behalf of the bidder;
4. Each person whose signature appears on the accompanying bid has been authorized by the bidder to determine the terms of, and to sign, the bid, on behalf of the bidder;
5. For the purposes of this Certificate and the accompanying bid, I understand that the word "competitor" shall include any individual or organization, other than the bidder, whether or not affiliated with the bidder, who:
 - (a) has been requested to submit a bid in response to this bid invitation;
 - (b) could potentially submit a bid in response to this bid invitation, based on their qualifications, abilities or experience; and
 - (c) provides the same goods and services as the bidder and/or is in the same line of business as the bidder
6. The bidder has arrived at the accompanying bid independently from, and without consultation, communication, agreement or arrangement with any competitor. However communication between partners in a joint venture or consortium³ will not be construed as collusive bidding.
7. In particular, without limiting the generality of paragraphs 6 above, there has been no consultation, communication, agreement or arrangement with any competitor regarding:

- (a) prices;
 - (b) geographical area where product or service will be rendered (market allocation)
 - (c) methods, factors or formulas used to calculate prices;
 - (d) the intention or decision to submit or not to submit, a bid;
 - (e) the submission of a bid which does not meet the specifications and conditions of the bid; or
 - (f) bidding with the intention not to win the bid.
8. In addition, there have been no consultations, communications, agreements or arrangements with any competitor regarding the quality, quantity, specifications and conditions or delivery particulars of the products or services to which this bid invitation relates.
9. The terms of the accompanying bid have not been, and will not be, disclosed by the bidder, directly or indirectly, to any competitor, prior to the date and time of the official bid opening or of the awarding of the contract.
10. I am aware that, in addition and without prejudice to any other remedy provided to combat any restrictive practices related to bids and contracts, bids that are suspicious will be reported to the Competition Commission for investigation and possible imposition of administrative penalties in terms of section 59 of the Competition Act No 89 of 1998 and or may be reported to the National Prosecuting Authority (NPA) for criminal investigation and or may be restricted from conducting business with the public sector for a period not exceeding ten (10) years in terms of the Prevention and Combating of Corrupt Activities Act No 12 of 2004 or any other applicable legislation.

.....
Signature

.....
Date

.....
Position

.....
Name of Bidder

MBD 6.1

PREFERENCE POINTS CLAIM FORM IN TERMS OF THE PREFERENTIAL PROCUREMENT REGULATIONS 2017

This preference form must form part of all bids invited. It contains general information and serves as a claim form for preference points for Broad-Based Black Economic Empowerment (B-BBEE) Status Level of Contribution

NB: BEFORE COMPLETING THIS FORM, BIDDERS MUST STUDY THE GENERAL CONDITIONS, DEFINITIONS AND DIRECTIVES APPLICABLE IN RESPECT OF B-BBEE, AS PRESCRIBED IN THE PREFERENTIAL PROCUREMENT REGULATIONS, 2017.

1. GENERAL CONDITIONS

1.1 The following preference point systems are applicable to all bids:

- the 80/20 system for requirements with a Rand value of up to R50 000 000 (all applicable taxes included); and
- the 90/10 system for requirements with a Rand value above R50 000 000 (all applicable taxes included).

1.2

- a) The value of this bid is estimated to exceed/not exceed R50 000 000 (all applicable taxes included) and therefore the preference point system shall be applicable; or
- b) Either the 80/20 or 90/10 preference point system will be applicable to this tender (*delete whichever is not applicable for this tender*).

1.3 Points for this bid shall be awarded for:

- (a) Price; and
- (b) B-BBEE Status Level of Contributor.

1.4 The maximum points for this bid are allocated as follows:

	POINTS
PRICE	
B-BBEE STATUS LEVEL OF CONTRIBUTOR	
Total points for Price and B-BBEE must not exceed	100

1.5 Failure on the part of a bidder to submit proof of B-BBEE Status level of contributor together with the bid, will be interpreted to mean that preference points for B-BBEE status level of contribution are not claimed.

1.6 The purchaser reserves the right to require of a bidder, either before a bid is adjudicated or at any time subsequently, to substantiate any claim in regard to preferences, in any manner required by the purchaser.

2. DEFINITIONS

- (a) “**B-BBEE**” means broad-based black economic empowerment as defined in section 1 of the Broad-Based Black Economic Empowerment Act;
- (b) “**B-BBEE status level of contributor**” means the B-BBEE status of an entity in terms of a code of good practice on black economic empowerment, issued in terms of section 9(1) of the Broad-Based Black Economic Empowerment Act;
- (c) “**bid**” means a written offer in a prescribed or stipulated form in response to an invitation by an organ of state for the provision of goods or services, through price quotations, advertised competitive bidding processes or proposals;
- (d) “**Broad-Based Black Economic Empowerment Act**” means the Broad-Based Black Economic Empowerment Act, 2003 (Act No. 53 of 2003);
- (e) “**EME**” means an Exempted Micro Enterprise in terms of a code of good practice on black economic empowerment issued in terms of section 9 (1) of the Broad-Based Black Economic Empowerment Act;
- (f) “**functionality**” means the ability of a tenderer to provide goods or services in accordance with specifications as set out in the tender documents.
- (g) “**prices**” includes all applicable taxes less all unconditional discounts;
- (h) “**proof of B-BBEE status level of contributor**” means:
 - 1) B-BBEE Status level certificate issued by an authorized body or person;
 - 2) A sworn affidavit as prescribed by the B-BBEE Codes of Good Practice;
 - 3) Any other requirement prescribed in terms of the B-BBEE Act;
- (i) “**QSE**” means a qualifying small business enterprise in terms of a code of good practice on black economic empowerment issued in terms of section 9 (1) of the Broad-Based Black Economic Empowerment Act;
- (j) “**rand value**” means the total estimated value of a contract in Rand, calculated at the time of bid invitation, and includes all applicable taxes;

3. POINTS AWARDED FOR PRICE

3.1 THE 80/20 OR 90/10 PREFERENCE POINT SYSTEMS

A maximum of 80 or 90 points is allocated for price on the following basis:

80/20 **or** **90/10**

$$P_s = 80 \left(1 - \frac{P_t - P_{\min}}{P_{\min}} \right) \quad \text{or} \quad P_s = 90 \left(1 - \frac{P_t - P_{\min}}{P_{\min}} \right)$$

Where

P_s = Points scored for price of bid under consideration

P_t = Price of bid under consideration

P_{\min} = Price of lowest acceptable bid

4. POINTS AWARDED FOR B-BBEE STATUS LEVEL OF CONTRIBUTOR

- 4.1 In terms of Regulation 6 (2) and 7 (2) of the Preferential Procurement Regulations, preference

points must be awarded to a bidder for attaining the B-BBEE status level of contribution in accordance with the table below:

B-BBEE Status Level of Contributor	Number of points (90/10 system)	Number of points (80/20 system)
1	10	20
2	9	18
3	6	14
4	5	12
5	4	8
6	3	6
7	2	4
8	1	2
Non-compliant contributor	0	0

5. BID DECLARATION

5.1 Bidders who claim points in respect of B-BBEE Status Level of Contribution must complete the following:

6. B-BBEE STATUS LEVEL OF CONTRIBUTOR CLAIMED IN TERMS OF PARAGRAPHS 1.4 AND 4.1

6.1 B-BBEE Status Level of Contributor: . =(maximum of 10 or 20 points)
 (Points claimed in respect of paragraph 7.1 must be in accordance with the table reflected in paragraph 4.1 and must be substantiated by relevant proof of B-BBEE status level of contributor.

7. SUB-CONTRACTING

7.1 Will any portion of the contract be sub-contracted?

(Tick applicable box)

YES	<input type="checkbox"/>	NO	<input type="checkbox"/>
-----	--------------------------	----	--------------------------

7.1.1 If yes, indicate:

- i) What percentage of the contract will be subcontracted.....%
- ii) The name of the sub-contractor.....
- iii) The B-BBEE status level of the sub-contractor.....
- iv) Whether the sub-contractor is an EME or QSE

(Tick applicable box)

YES	<input type="checkbox"/>	NO	<input type="checkbox"/>
-----	--------------------------	----	--------------------------

v) Specify, by ticking the appropriate box, if subcontracting with an enterprise in terms of Preferential Procurement Regulations,2017:

Designated Group: An EME or QSE which is at last 51% owned by:

EME
√

QSE
√

Black people
 Black people who are youth

Black people who are women
Black people with disabilities
Black people living in rural or underdeveloped areas or townships
Cooperative owned by black people
Black people who are military veterans

OR

Any EME
Any QSE

8. DECLARATION WITH REGARD TO COMPANY/FIRM

8.1 Name of company/firm.....

8.2 VAT registration number:.....

8.3 Company registration number:.....

8.4 TYPE OF COMPANY/ FIRM

- Partnership/Joint Venture / Consortium
 - One person business/sole propriety
 - Close corporation
 - Company
 - (Pty) Limited
- [TICK APPLICABLE BOX]

8.5 DESCRIBE PRINCIPAL BUSINESS ACTIVITIES

.....
.....
.....
.....

8.6 COMPANY CLASSIFICATION

- Manufacturer
 - Supplier
 - Professional service provider
 - Other service providers, e.g. transporter, etc.
- [TICK APPLICABLE BOX]

8.7 MUNICIPAL INFORMATION

Municipality where business is situated:

Registered Account Number:

Stand Number:.....

8.8 Total number of years the company/firm has been in business:.....

8.9 I/we, the undersigned, who is / are duly authorised to do so on behalf of the company/firm, certify that the points claimed, based on the B-BBE status level of contributor indicated in paragraphs 1.4 and 6.1 of the foregoing certificate, qualifies the company/ firm for the preference(s) shown and I / we acknowledge that:

- i) The information furnished is true and correct;
- ii) The preference points claimed are in accordance with the General Conditions as indicated in paragraph 1 of this form;
- iii) In the event of a contract being awarded as a result of points claimed as shown in paragraphs 1.4 and 6.1, the contractor may be required to furnish documentary proof to the satisfaction of the purchaser that the claims are correct;
- iv) If the B-BBEE status level of contributor has been claimed or obtained on a fraudulent basis or any of the conditions of contract have not been fulfilled, the purchaser may, in addition to any other remedy it may have –
 - (a) disqualify the person from the bidding process;
 - (b) recover costs, losses or damages it has incurred or suffered as a result of that person's conduct;
 - (c) cancel the contract and claim any damages which it has suffered as a result of having to make less favourable arrangements due to such cancellation;
 - (d) recommend that the bidder or contractor, its shareholders and directors, or only the shareholders and directors who acted on a fraudulent basis, be restricted by the National Treasury from obtaining business from any organ of state for a period not exceeding 10 years, after the *audi alteram partem* (hear the other side) rule has been applied; and
 - (e) forward the matter for criminal prosecution.

<p>WITNESSES</p> <p>1.</p> <p>2.</p>
--

<p>.....</p> <p>SIGNATURE(S) OF BIDDERS(S)</p>
<p>DATE:</p> <p>ADDRESS</p> <p>.....</p> <p>.....</p>

SWORN AFFIDAVIT – B-BBEE EXEMPTED MICRO ENTERPRISE

I, the undersigned,

Full name & Surname	
Identity number	

1. I hereby declare under oath as follows:

- That the contents of this statement are to the best of my knowledge a true reflection of the facts.
- That I am a member / director / owner of the following enterprise and am duly authorised to act on its behalf:

Enterprise Name	
Trading Name	
Registration Number	
Enterprise Address	

3. I hereby declare under oath that:

- The enterprise is _____% black owned;
- The enterprise is _____% black woman owned;
- Based on the management accounts and other information available on the _____ financial year, the income did not exceed R10, 000,000.00 (ten million rands);

Please confirm on the table below the B-BBEE level contributor, **by ticking the applicable box.**

100% black owned	Level One (135% B-BBEE procurement recognition)	
More than 51% black owned	Level Two (125% B-BBEE procurement recognition)	
Less than 51% black owned	Level Four (100% B-BBEE procurement recognition)	

4. The entity is an empowering supplier in terms of the **DTI** Codes of Good Practice.

5. I know and understand the contents of this affidavit and I have no objection to take the prescribed oath and consider the oath binding on my conscience and on the owners of the enterprise which I represent in this matter.

6. The sworn affidavit will be valid for a period of 12 months from the date signed by Commissioner.

Respondents Signature: _____ **Date:** _____

Commissioner of Oaths Signature _____
& Stamp

ANNEXURE A
TERMS OF REFERENCE
THE PROCUREMENT OF PIKITUP BRANDED MARKETING COLLATERAL FOR USE AT PIKITUP

1. PURPOSE

The purpose of this briefing document is to source a credible service provider with expertise in branding selected corporate branding for Pikitup.

2. BACKGROUND

Corporate Branding is a marketing tool used for brand awareness, brand presence and to showcase relevant messages and campaigns at Pikitup. These items are used during events and functions that happen

3. OBJECTIVES

- 3.1. To improve Pikitup brand awareness to key stakeholders and public.
- 3.2. Promote Pikitup key messages/campaigns and functions

4. SCOPE OF WORK

- Delivery date – no later than 25 Nov 2020.
- Deliver address – 66 Jorissen Place, Jorissen Street, Braamfontein.
- Design and create artwork – provide design reverts.
- Looking for high quality materials, strong, sturdy –
- Must include a 12month warranty should anything be defective or break (factory faults or other) – where you will collect and repair and deliver back to us.
- Items – see below table spec.

Description	Quantity	Specs
Gazebo	4 x	See attached image for spec
Wall banners	2x (1x curved, 1x expanding)	See attached image
Branded Roll up banners (with design) – large	2x large	See attached image
Branded Table Cloths – loose	4x (2x green)(2x black)	See attached image
Flag Banners	6x (3x large, 3x Extra large)	See attached image

Lantern banners	4x (2100 mm)	See attached image
-----------------	--------------	--------------------

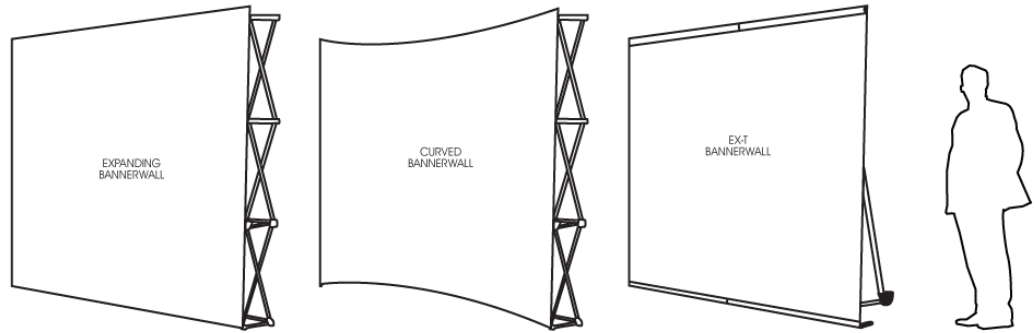

EXPANDING BANNERWALL

- ▲ 2.25 m (7' 4")
- ▶ 3.00 m (9' 10") - 4.00 (13')
- 11.4 kg (8.82 lb) - 15.2kg (33.5lb)

CURVED BANNERWALL

- ▲ 2.25 m (7' 4")
- ▶ 3.00 m (9' 10")
- 12 kg (50.7lb)

EX-T BANNERWALL

- ▲ 2.5 m (8' 2")
- ▶ 3.00 m (9' 10") - 4.50 m (14'9")
- 6.5 kg (14.33 lb) - 9kg (19.8lb)

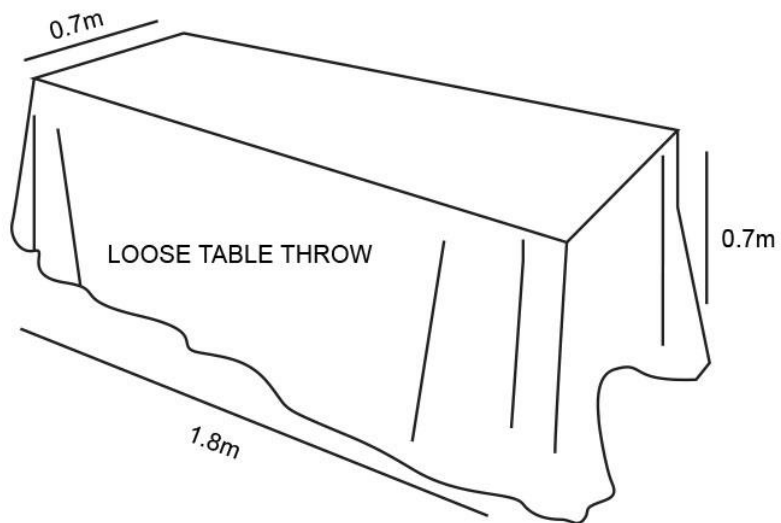
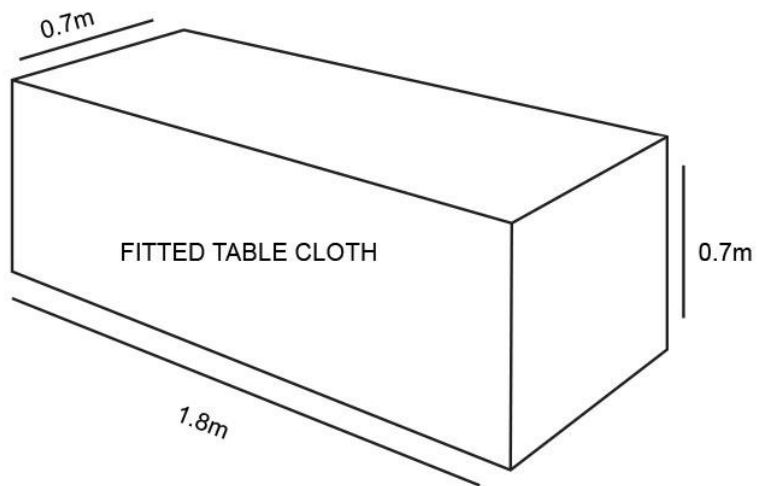

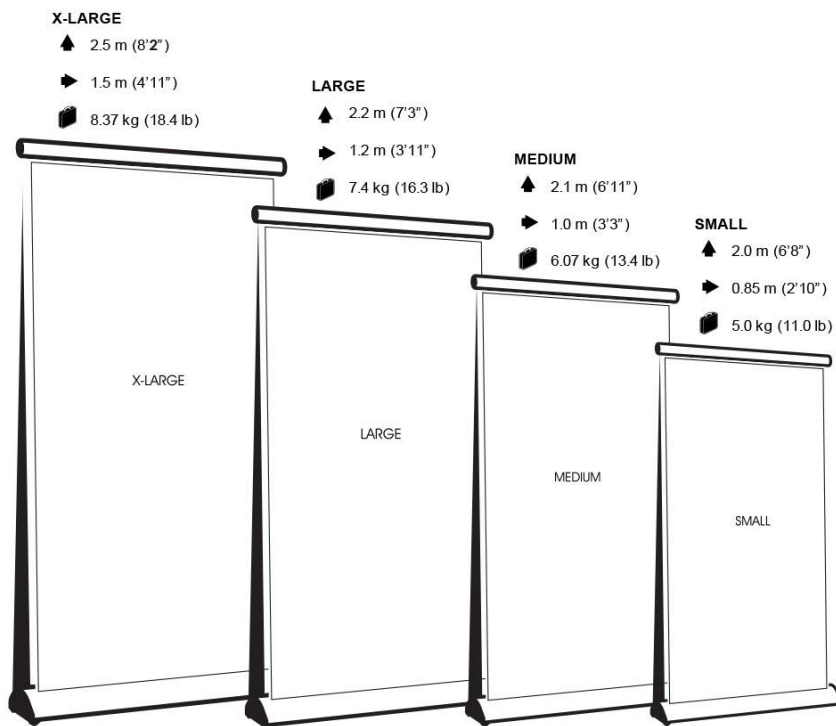
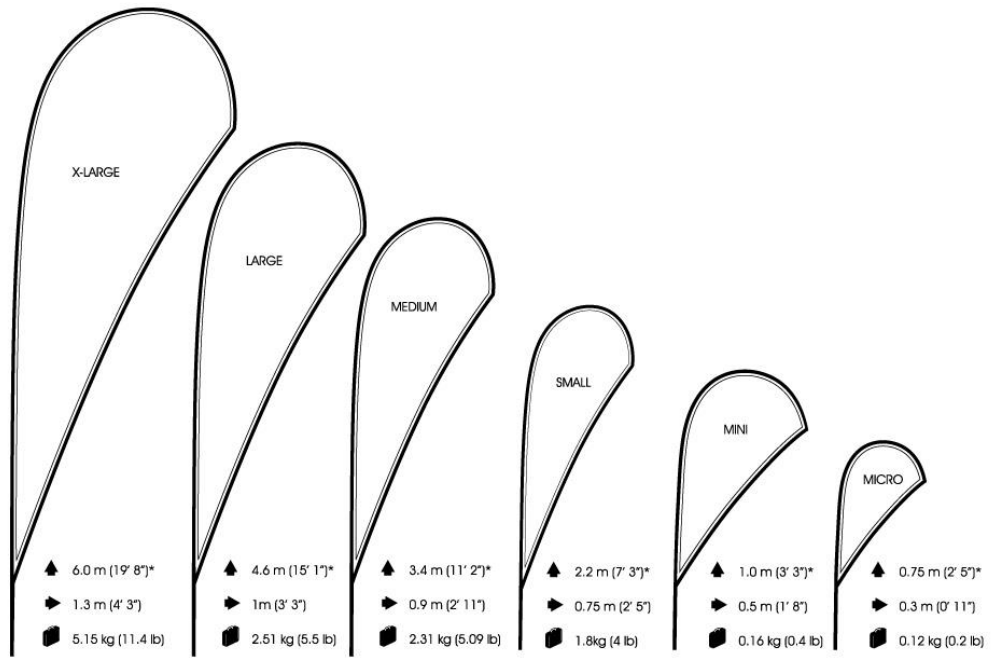

Gazebo (Premium Aluminium)

3M PREMIUM ALUMINIUM GAZEBO

Size:
3m x 3m

Weight
30kg

Frame
Outer Leg: Ø40 x 1.6mm
Inner Leg: Ø33.6 x 1.6mm
Cross Bar: 32 x 16 x 2.0mm

4.5M PREMIUM ALUMINIUM GAZEBO

Size:
3m x 4.5m

Weight
40kg

Frame
Outer Leg: Ø40 x 1.6mm
Inner Leg: Ø33.6 x 1.6mm
Cross Bar: 32 x 16 x 2.0mm

6M PREMIUM ALUMINIUM GAZEBO

Size:
3m x 6m

Weight
50kg

Frame
Outer Leg: Ø40 x 1.6mm
Inner Leg: Ø33.6 x 1.6mm
Cross Bar: 32 x 16 x 2.0mm

GAZEBO SPECIFICATIONS

- Dye-sublimation printing with UV Japanese inks
- Fabric: 100% Coated Polyester (240gsm)
- Includes: Branded roof, easyfold gazebo frame, bag, pegs and rope.
- Boxes for packaging and protections of Gazebos must be ordered for any couriering.



Product Assembly



Please request templates and artwork guidelines for design purposes.